

SPECIFICATIONS

FOR

SALISBURY MEMORIAL PARK

Updated: 10 November 2020

ADMINISTRATIVE OFFICE
CITY OF SALISBURY
34 CHURCH STREET, SALISBURY 5108
TELEPHONE: 08 8406 8317
FAX: 08 8281 5466
EMAIL: cemetery@salisbury.sa.gov.au

CEMETERY
2 SPAINS ROAD SALISBURY DOWNS SA 5108
TELEPHONE: 08 8406 8317

TABLE OF CONTENTS

TABLE OF CONTENTS	2
DEFINITIONS:	3
SPECIFICATIONS	4
1. STANDARD MONUMENT	4
2A LEDGER GRAVE.....	4
2B LEDGER MONUMENT	5
3. VAULT MONUMENT	5
4. VAULT GRAVE	6
5. CHILDREN’S MONUMENT	6
6. ROSE AND SHRUB GARDEN URNS	6

SMP provides the following services:-

Licences, Burials, Placement of Cremated Remains, Erection of Monuments etc. and these are available in the following sections:-

- Lawn Section
- Old Section
- Catholic Section
- Church of England Section
- Lutheran Section
- Orthodox Section
- Ledger Section
- Vault Section
- Children’s Section
- Stillborn Section
- Cremation Memorials in Rose Gardens & Niche Walls
- Cremation Memorials in Shrub Garden
- Wall of Life & Memories
- Memorial Seats
- Mausoleum (issue of licences subject to a joint Council/Private Sector lease development)

SPECIFICATIONS OF SALISBURY MEMORIAL PARK

These specifications are to be read in conjunction with:

**The Local Government Act 1934 Part 30 (Cemeteries)
The Local Government (Cemetery) Regulations 1995
Occupational Health & Safety Act 2000 No 40**

DEFINITIONS:

In these specifications:-

“Licensee” means any person in whose name a space is currently recorded in the records of Salisbury Memorial Park as the owner of the exclusive right to interment or entombment.

“Interment” means the disposition of the remains of a deceased person by burial in the earth.

“Inurnment” means the disposition of the cremated remains of a deceased person either by burial in the earth or by placement within a cremation space.

“Entombment” means the disposition of the remains of a deceased person in a mausoleum or crypt, constructed for such purpose by Salisbury Memorial Park.

“Memorial plaque or monument” means the type of plaque or memorial stone allowed by Salisbury Memorial Park to be placed on a space.

“Space” means the space in which interments, inurnments or entombments may be made.

“Park” means the cemetery to which the Rules and Regulations relate.

“Exhumation” the lawful removal of human remains from their registered location within the Salisbury Memorial Park.

“Memorial Work” all masonry and monumental works associated with an exhumation/relocation request.

“Unit” a five year extension of lease.

“Companion Site” a site purchased immediately to the left or right of the original site.

“Reservation Fee” the fee payable to reserve a specific site for a period of five years.

SPECIFICATIONS

1. STANDARD MONUMENT

- 1.1 In all lawn areas of the Park, monuments must not exceed 900mm in height, such measurement to be taken from the top of the concrete plinth provided by the City of Salisbury.
- 1.2 Single monuments shall not be more than 900mm wide or exceed 280mm thick.
- 1.3 In all lawn areas double monuments shall not exceed 1800mm in width, and in all other respects be constructed consistent with the measurements for single monuments.
- 1.4 In the old section D,F,A & B single monuments must not exceed 1100mm in height, such measurement to be taken from the top of the concrete plinth. The width of the monument must not exceed 1300mm, nor the length 2700mm. Concrete foundations will be constructed to establish gravesite prior to any monument being erected.
- 1.5 In the older section D,F,A & B double monuments shall be 2600mm wide, and in other respects be constructed consistent with the measurements for single monuments.
- 1.6 Grave identification numbers are to be painted on the concrete plinth for each monument in numbers no less than 20mm high.
- 1.7 In the Orthodox section single monuments must not exceed 900mm in height, such measurement to be taken from the top of the concrete plinth. The width of the monument must not exceed 900mm, nor the thickness exceed 280mm. Double monuments shall not exceed 1800mm in width, and in all other aspects be constructed consistent with the measurements for single monuments.

2. STANDARD GRAVE

- 2.1 In all lawn areas a single grave must be 2400mm x 1000mm.
- 2.2 Double width graves are acceptable and must be 2400mm x 2000mm.
In the old section D,F, A & B a single grave must be 2500mm x 1250mm
- 2.3 Double width graves are acceptable and must be 2500mm x 2500mm.

2A LEDGER GRAVE

- 2A.1 In the ledger section a single grave must be 2700mm in length and 1350mm in width.

2B LEDGER MONUMENT

- 2B.1 In the ledger section single monuments must not exceed 1650mm in height, such measurement to be taken from the top of the paving level. The width of the monument must not exceed 1250mm nor the length 2650mm. Concrete foundations are required to be constructed prior to any monument being erected. Double monuments shall not exceed 2500mm in width, and in all other respects be constructed consistent with the measurements for single monuments. The top of the ledger must be 400mm from the paving level. A walkway between graves is to be covered by a natural stone strip 50mm thick. Where two surfaces are joined, dowels are required. Monuments must be installed within twelve months of the first interment in a ledger space or spaces.

PLANS: LEDGER MONUMENT MEASUREMENTS

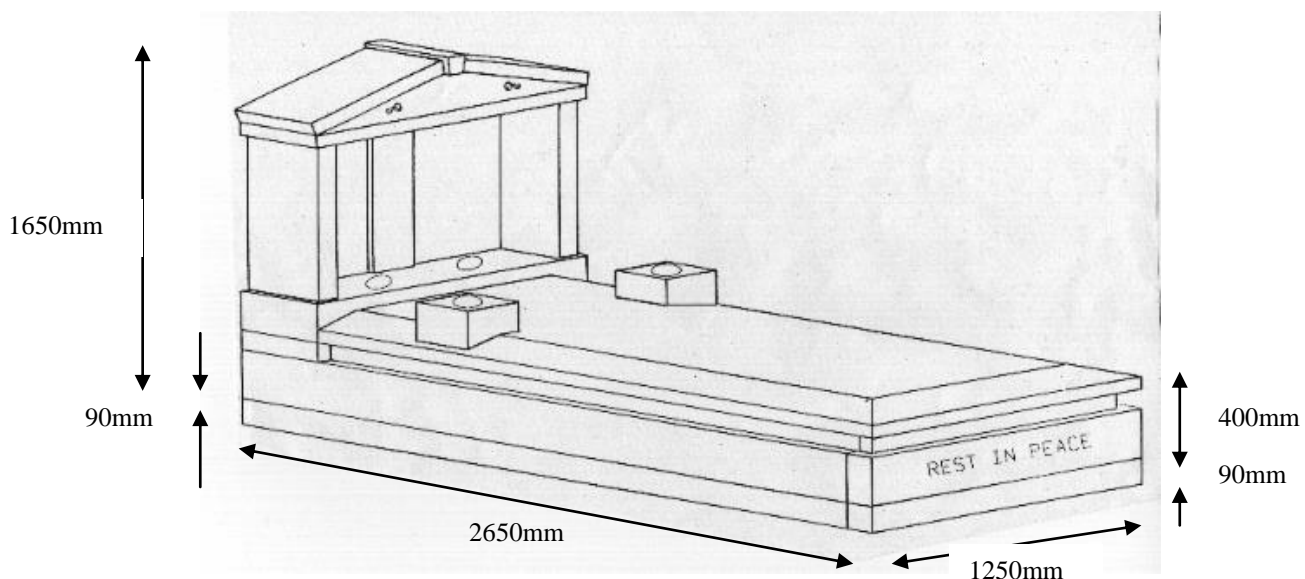

3. VAULT MONUMENT

- 3.1 In the new lawn section, single monuments must not exceed 900mm in height, such measurement to be taken from the top of the concrete plinth. The width of the monument must not exceed 1200mm, nor the depth exceed 280mm.
- 3.2 In the new section double monuments shall be 2400mm, and in all other respects be constructed consistent with the measurements of a single vault.
- 3.2 In the vault section, section "V" the width of the monument must not exceed 1200mm nor the length exceed 2650mm for a single monument. For multiple use, the monument must be constructed consistent with the measurement for single monuments. A walkway/(Tread) between graves is to be covered by an Australian Black Granite stone strip 50mm thick. Where two surfaces are joined, dowels are required. Monuments must be installed within twelve months of the first entombment in a vault or vaults.

4. VAULT GRAVE

- 4.1 In the lawn areas a single grave must be 2600mm x 1200mm.
- 4.2 Double width graves are acceptable and must be 2600mm x 2400mm
- 4.3 In the vault section, section “V” the dimensions must be 2650mm in length and 1500mm in width. A concrete constructed vault with internal measurements of approximately 2200mm in length and 900mm in width and depth to accommodate two caskets or coffins. The aperture must be checked before determining the casket size.
- 4.4 Vaults from Cooke Precast Concrete Pty Ltd previously utilised in the lawn sections at Salisbury Memorial Park are no longer approved unless provision has been made for an additional single vault to be installed upon an existing single vault. This installation shall be undertaken solely by the Manager – Cemetery Services and his staff (dated 1/8/99). Consideration shall be given to any application forwarded to the Manager –Cemetery Services for the use of a vault from Cooke Precast Concrete Pty Ltd. Upon the acceptance of such application, the purchase and subsequent installation of such a vault shall be completed by the Manager – Cemetery Services and his staff and charged to the client at the prevailing rates.

5. CHILDREN’S MONUMENT

- 5.1 In the children’s section, monuments must not exceed 750mm in height, such measurement to be taken from the top of the concrete plinth. The width of the monument must not exceed 850mm, nor the depth exceed 280mm.
- 5.2 Grave identification numbers are to be painted on the concrete plinth for each monument in numbers not less than 20mm high.

6. ROSE AND SHRUB GARDEN URNS

- 6.1 Urns shall be constructed in accordance with the City of Salisbury specifications.
- 6.2 Granite plaques in lieu with inscription shall be fixed to the urn.
- 6.3 Tributes may only be place in approved receptacles.
- 6.4 The base of the urn is to be positioned to the concrete plinth surrounding the garden bed.
- 6.5 Position of urns will be in accordance with the number on the reservation licence.